

# Storm Pro Banner Stand

UB204

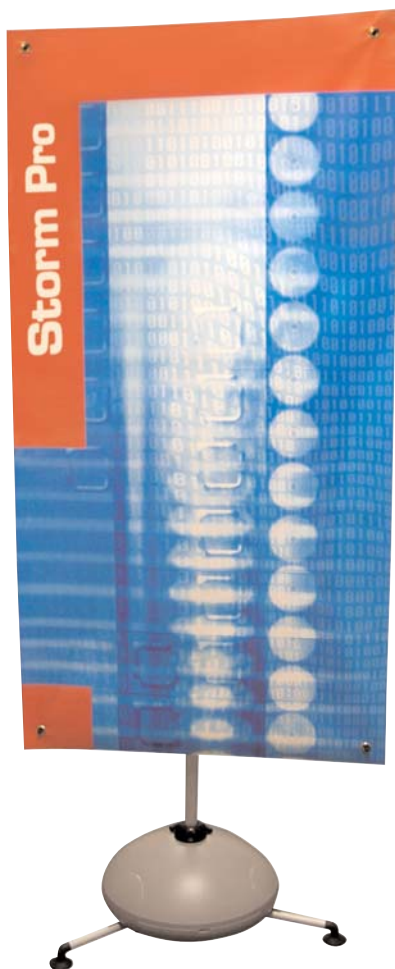

The Storm Pro has a heavy duty construction for strength and a compact hollow base that can be filled with water or sand for weighting, making it highly portable. The additional feature of extending stabiliser feet makes the system extra stable for outdoor use.

The telescopic support pole and completely adjustable central hub allow you to vary the height, width and orientation of the graphic to fit your needs.

## features & benefits

- Single sided banner, max. graphic size 2185mm (h) x 813mm (w)
- Heavy duty construction with extending stabiliser feet for strength and stability
- Telescopic aluminium support pole and adjustable central hub allows you to vary height and width and rotation of graphic
- Hollow plastic base for water weighting
- Includes bag

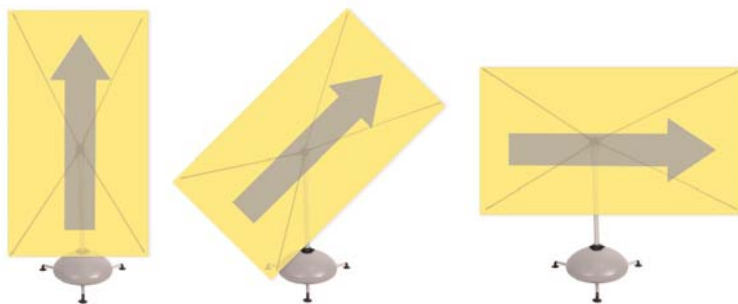

The adjustable rotating central hub offers the option of presenting your graphic in a range of choices including vertical, at a 45 degree angle or completely horizontal.

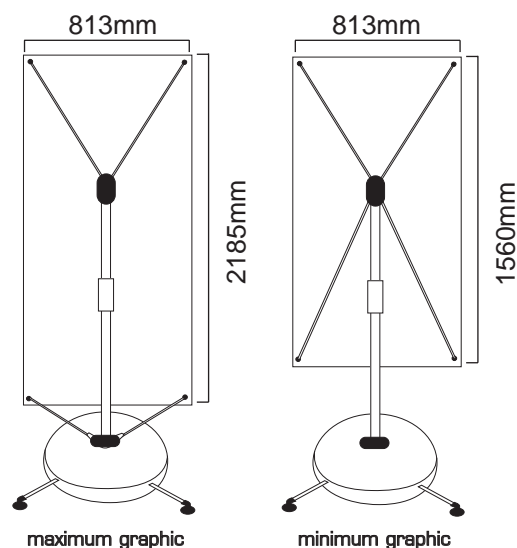

## hardware specifications

Hardware Dimensions (mm)  
2600 (h - max) x 990 (w - max) or  
730 (w - min) x 820 (d - max) or  
730 (d - min)

Weight:  
3kg approx - 21.3kg approx when  
unit is filled with water (approx 18  
litres in total)

## graphic specifications

Minimum Graphic Dimensions (mm):  
1575 (h) x 813 (w)  
Maximum Graphic Dimensions (mm):  
2185(h) x 813(w)  
Substrate:  
Woven PVC banner material.  
Recommend 13mm eyelets

## additional info

Included in kit:  
Bag, base, telescopic pole, carbon  
rods

availability:  
Grey

UI135B REV 1 04/05

# Assembly Instructions

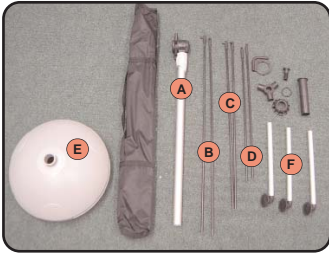

Kit includes: Telescopic pole (A), carbon rods x 6 (B/C/D), water tank (E), water tank feet x 3 (F), rod bracket, water tank cap, telescopic pole holder, water tank foot holder, rubber ring, screw lock



1 Turn the water tank over and place the water tank foot holder over the hole in the base.



2 Take the screw lock and place through the water tank foot holder, through the hole in the base. Screw tightly to secure fit.

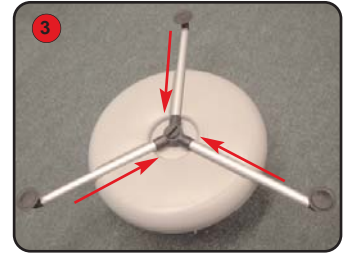

3 Push each water tank foot securely into the foot holder, making sure the fit is tight.



4 Turn the base onto its feet and place the v-shaped rod bracket over the hole.



5 Place the rubber ring over the telescopic pole holder and insert through the hole into the water tank.



6 Take the water tank cap and place over the hole. Thread loosely but not tight. Fill tank with water (approx. 18 litres).



7 Place the telescopic pole through the hole into the water tank and then screw the cap tight for a secure fit.



8 Carbon rods (B - large) fit into the lower arms, carbon rods (C - medium) fit into the two upper arms and carbon rods (D - small) fit into the v-shaped rod bracket if required.

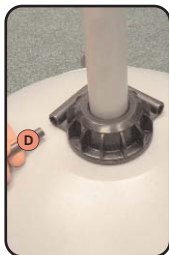

9 Screw the back of the rotary lock when into position. When loosened the head can spin 360 degrees and carbon rods can move outwards to adjust width.

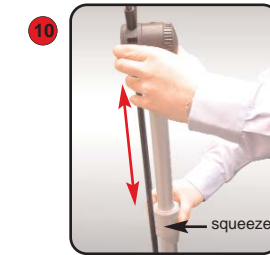

10 To adjust height of telescopic pole, squeeze the middle grip on the pole and then pull from the top to click into position.

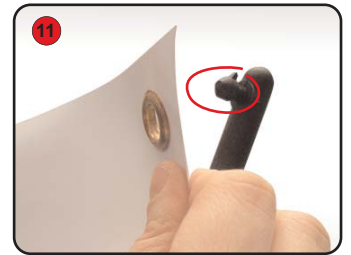

11 Finally, attach the graphic at each corner by threading the eyelet over the pip of each carbon rod.

Other products in our outdoor retail range include:

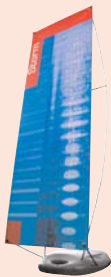

## Storm

Single sided banner with hollow plastic base for water or sand weighting. Supported on simple eyelet system. Weather resistant.



## Horizon

Indoor or outdoor double sided banner with telescopic variable height up to 2500mm and extends to 3000mm wide but units can link together to form seamless wall.



## Wind Dancer Maxi

Telescopic flag pole, adjustable height up to 5300mm. Hollow base for water or sand weighting for total stability.



## Ultima Value

A range of price-driven modular display products with attractive discounts for bulk purchases and a 1 year product guarantee. The range focuses on our best selling commodity products such as pop-up kits, banner stands, panel kits and display accessories.

For any sales enquiry contact us on +44 (0) 1536 272250 or email [sales@ultimadisplays.co.uk](mailto:sales@ultimadisplays.co.uk)

Ultima Displays Ltd, 49-50 Causeway Rd, Earlstrees Industrial Estate, Corby, Northants NN17 4DU, UK

Tel: +44 (0) 1536 272250 Fax: +44 (0) 1536 272268 Web: [www.ultimadisplays.co.uk](http://www.ultimadisplays.co.uk)